

End Profile Grinding Machine

 **REINECKER**

made by
Ulmer Werkzeugschleiftechnik

SF 50 REINECKER

Discipline: Triathlon

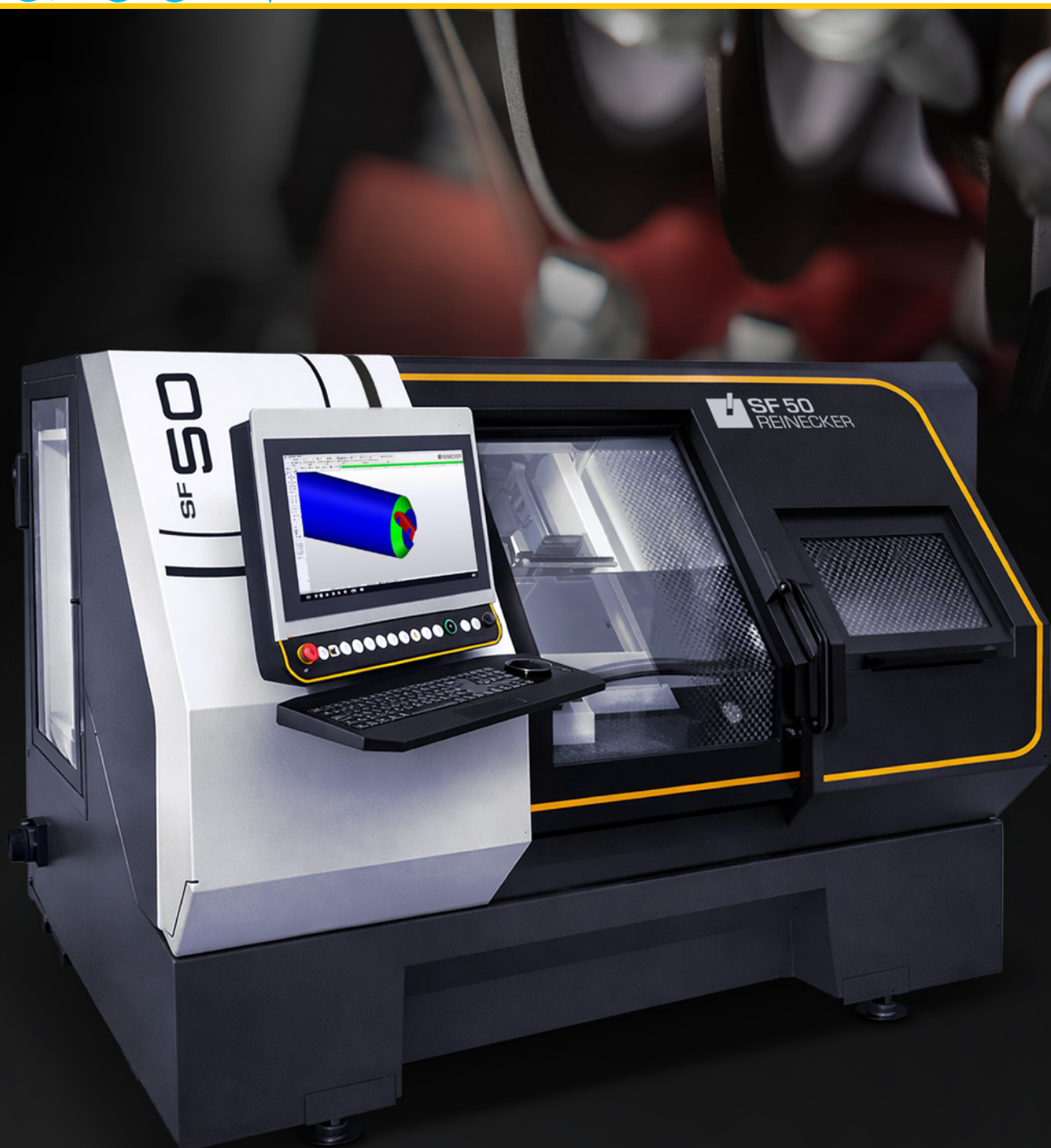

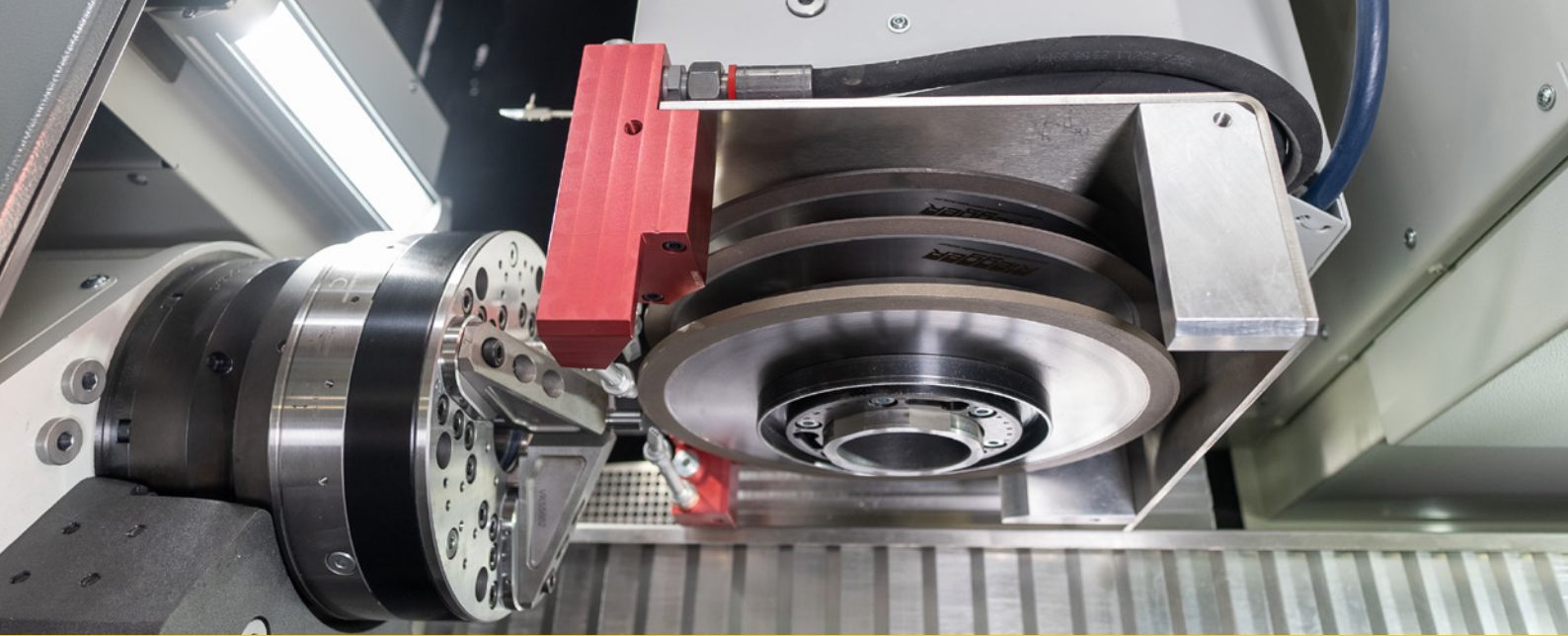

Good to know

- **Low setup effort**
 Up to four different grinding wheels can be mounted on one flange.
 Diameter max. 300 mm [11.8"].
 Power-actuated three-jaw chuck with interchangeable jaws for clamping ranges from diameter 3 mm [0.12"] to 32 mm [1.25"].
- **Process-optimized systems**
 Measuring system inside of the C-axis for automatic determination of the workpiece insertion depth. Automatic loading device with integrated turning station for small batch machining.
- **Ergonomics for maintenance and service**
 Easy and fast maintenance and repair due to good accessibility to service-relevant areas.
- **NUM Flexium+**
 CNC control with powerful NUM DriveX drives.
- **NUMROTOplus®**
 Programming system with 3D-capability.

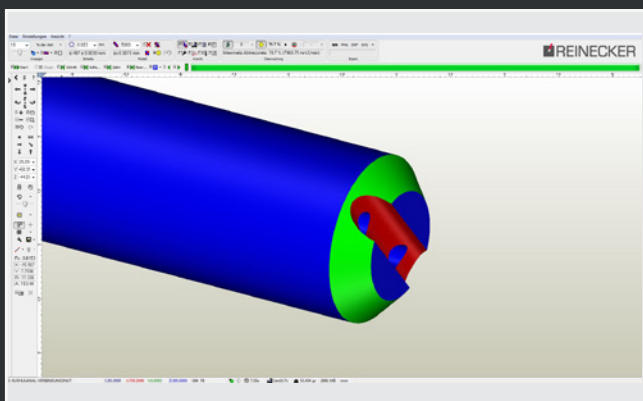

Application examples

■ Points



■ Chamfers

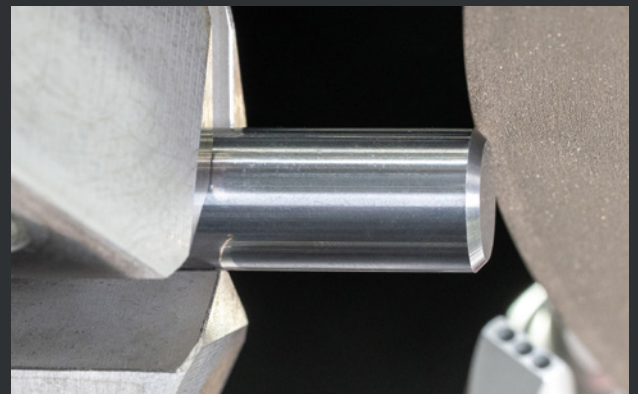

■ Grooves

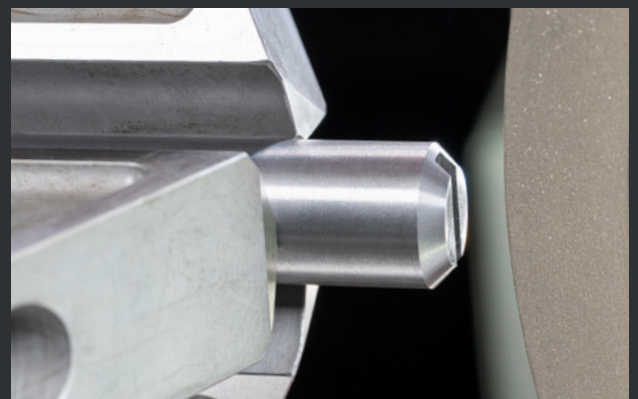

SF 50 REINECKER

Master in three challenges

Creation of points, chamfers, radii and connecting grooves of cooling channels and their combination at both ends of cylindrical tool blanks made from tungsten carbide, HSS and ceramic materials.



Turning station

Integrated turning station for both-end processing.



IR-Vision

Optical system for detecting the angular position of the cooling channels.



Loading device

with up to four pallets. Capacity (example):
Shank diameter 10 mm [0.4"] → 450 pieces.

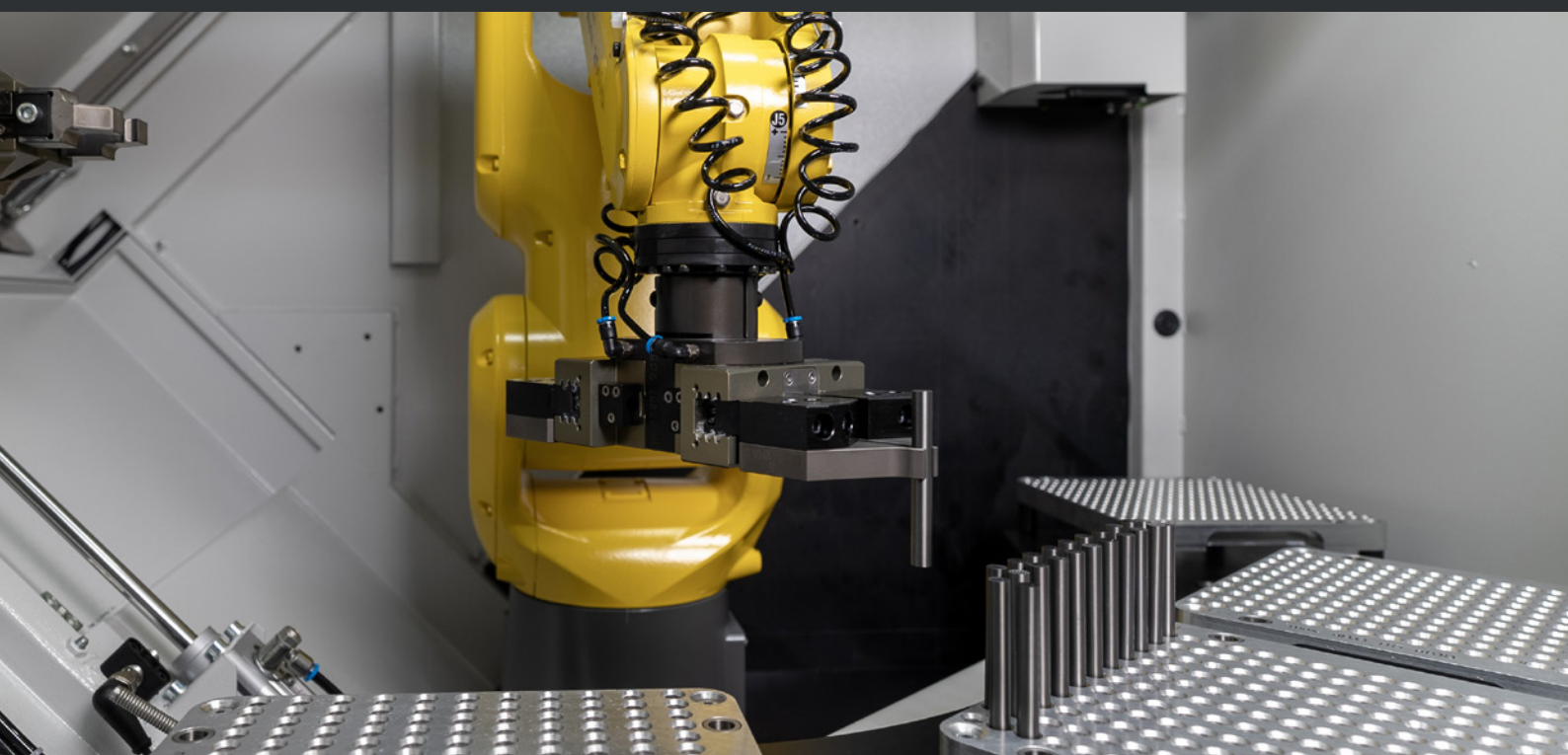

SF 50 REINECKER

Technical Details

EN 02 | 26

Performance Data SF 50

Travels of axes	X-axis	220 mm [8.7"]
	Z-axis	900 mm [35.4"]
Resolution	X-axis	0.0001 mm [4 millionths"]
	Z-axis	0.0001 mm [4 millionths"]
	C-axis	0.001°
Axis drives	X-axis	5 kN
	Z-axis	5 kN
	Rapid travel speeds X / Z	30 / 30 m/min
Grinding spindle	Motorized spindle	Ø 164 x 450 mm [6.5 x 17.7"]
	Nominal Power	11 kW [15 hp]
	Peak Power	17 kW [23 hp]
	Speed infinitely	up to 6,500 rpm
	Torque const. S6 _{60%}	20 Nm up to 5,500 rpm
	Grinding wheel-Ø max.	300 mm [11.8"]
	Tool holder	HSK-E80
Workpiece spindle	Interface attachment	Triple-jaw chuck
	Speed max.	2,000 rpm
	Torque max.	22 Nm
	Machine	Total connected load
Supply voltage / frequency		400 V – 50/60 Hz
Dimensions W x L x H		2,420 x 2,130 x 1,800 mm [95.3 x 83.9 x 70.9"]
Weight approx.		ca. 5.5 t [12,200 lbs]

Workpiece Dimensions

Manual loading	Ø max.	32 mm [1.25"]
	Length max.	450 mm [17.7"]
	Weight max.	20 kg [5.5 lbs.]
Workpiece automation	Ø max.	32 mm [1.25"]
	Length max.	450 mm [17.7"]
	Weight max.	2,5 kg [5.5 lbs.]

Kinematics

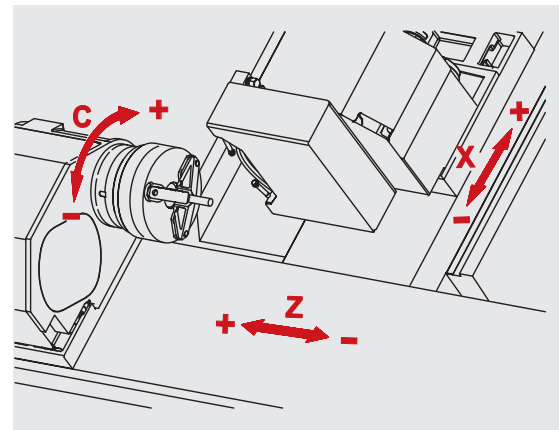

Dimensions in mm [inch]

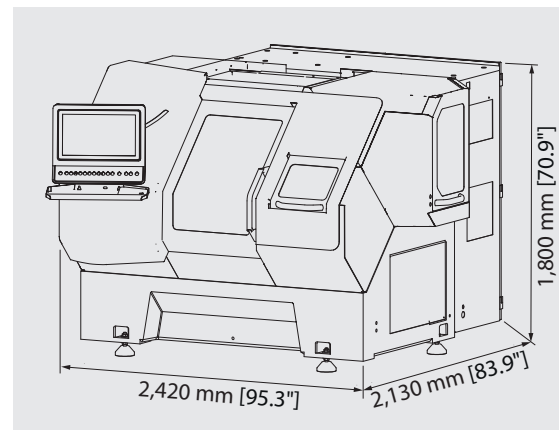

Ulmer Werkzeugschleiftechnik GmbH & Co.KG

August-Nagel-Str. 9
89079 Ulm-Eisingen, Germany
Tel. +49(0)7305/171-324
Fax +49(0)7305/171-328
info@werkzeugschleifen.de
www.werkzeugschleifen.de



REINECKER